



## Pusey & Jones Tester

**Standards:** ISO 7267-3, ASTM D 531



German  
Manufactured



Highest  
Accuracy and  
Repeatability



Industry  
Certified



Complete  
Calibration  
Solution



Free Proof of  
Concept



Custom  
Turnkey  
Solution  
Availability

**Video:** [https://youtu.be/S\\_cOk-6QbPI](https://youtu.be/S_cOk-6QbPI)

### Description:

Pusey & Jones is a rubber and rubber like material testing plastometer system. The unit is designed for testing rubber rollers in the paper industry. The system can test specimens with flat surfaces and thickness of 13 mm. This portable solution can be upgraded to the automatic test stand which allows for the ultimate accuracy and repeatability results regardless and elimination of operator error.

The system is equipment with an intuitive electronic dial gauge which indicates the penetration depth directly in 0.00 mm units and comes equipped with a zero-setting option. The primary benefit is that the dial gauge display can be set for zero by pressing a single button, as soon as the indenter with measuring rod is raised approximately for about 3 mm after lowering the body of the hardness tester. The integration of a vertical spindle found at the back of the testing system allows for accurate lowering or the lifting movements.

A specific test load of 9.8 N is applied by lowering the lateral load lever. The measurement results can be read after a 60 second testing time. This results can be displayed directly on the user-friendly digital interface of the Pusey & Jones system or on a PC should you choose to upgrade to the HardTest software. The latter feature allows to generate reports in Excel and PDF format for your optimal accuracy and ease of data management.

### Features:

- ✓ Built-In Timer for Precise and Repeatable Measurement
- ✓ 1kg load weight
- ✓ RS232 Output for Connection to Optional HardTest Software





## Ranges of Application:

Pusey & Kones this hardness method is for the hardness measuring on rubber or rubber-like materials and rubber rollers in the paper industry.

## Accessories:

- ✓ DAKKS/DKD-calibration certificate for the instrument
- ✓ Test stand for HPEII Barcol
- ✓ Software for Data Transfer and Analysis
- ✓ Standard test block with DAKKS/DKD-calibration certificate

## System Dimensions:

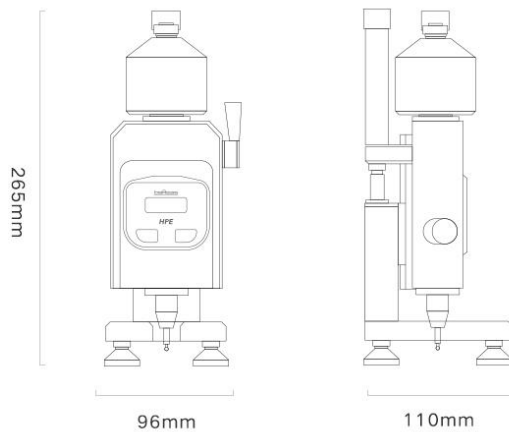

NEXTGEN  
MATERIAL TESTING

Height : 265mm

Width : 96mm

Depth : 110mm

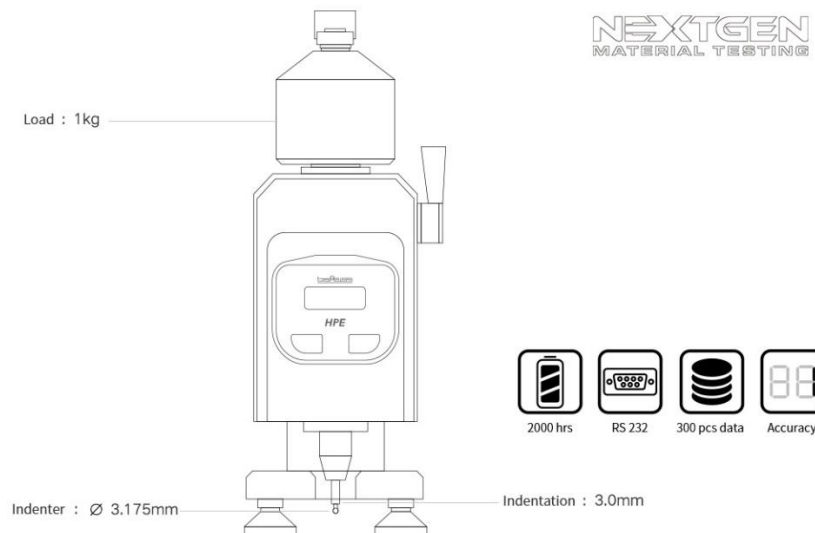

NEXTGEN  
MATERIAL TESTING



# NEXTGEN MATERIAL TESTING

YOUR QUALITY TESTING CHOICE

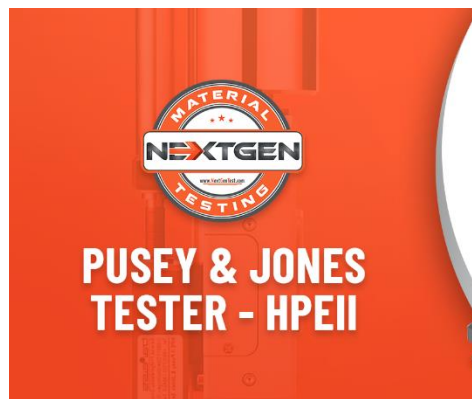

\* Request a [formal quotation](#) or send an e-mail to [sales@nextgentest.com](mailto:sales@nextgentest.com) for the most up-to-date pricing and applicable discounts and incentives

NORTH AMERICA (CORPORATE HEADQUARTERS): 170-422 Richards St., Vancouver, BC, V6B 2Z4 Canada

CALIFORNIA: 3503 Jack Northrop Ave., Suite # AF937, Hawthorne, CA 90250

Toll Free: +1 (888) 332-3582 | Fax: +1 905 247-0555 | [www.nextgentest.com](http://www.nextgentest.com)