



## Metals Impact Tester - Class H 750J - Single Column Charpy and Izod Impact Tester

### Standard

ASTM E23, ASTM E1820, ASTM E2298,  
ISO 148, EN10045, ISO 148, EN10045, ISO 14556,  
JIS Z 2242, GOST 9454-78

### Application:

- Impact on metals, Charpy, both non-instrumented and instrumented
- Servo motor driven pendulum can stop at any position, realizing different angle/energy impact test for R&D use
- Equipped with cooling system, I can perform low temperature test down to  $-180^{\circ}\text{C}$



### Machine Structure

The basic model consists of a heavy steel base on which the specimen holder (anvil) and a heavy-duty cast steel upright are mounted.

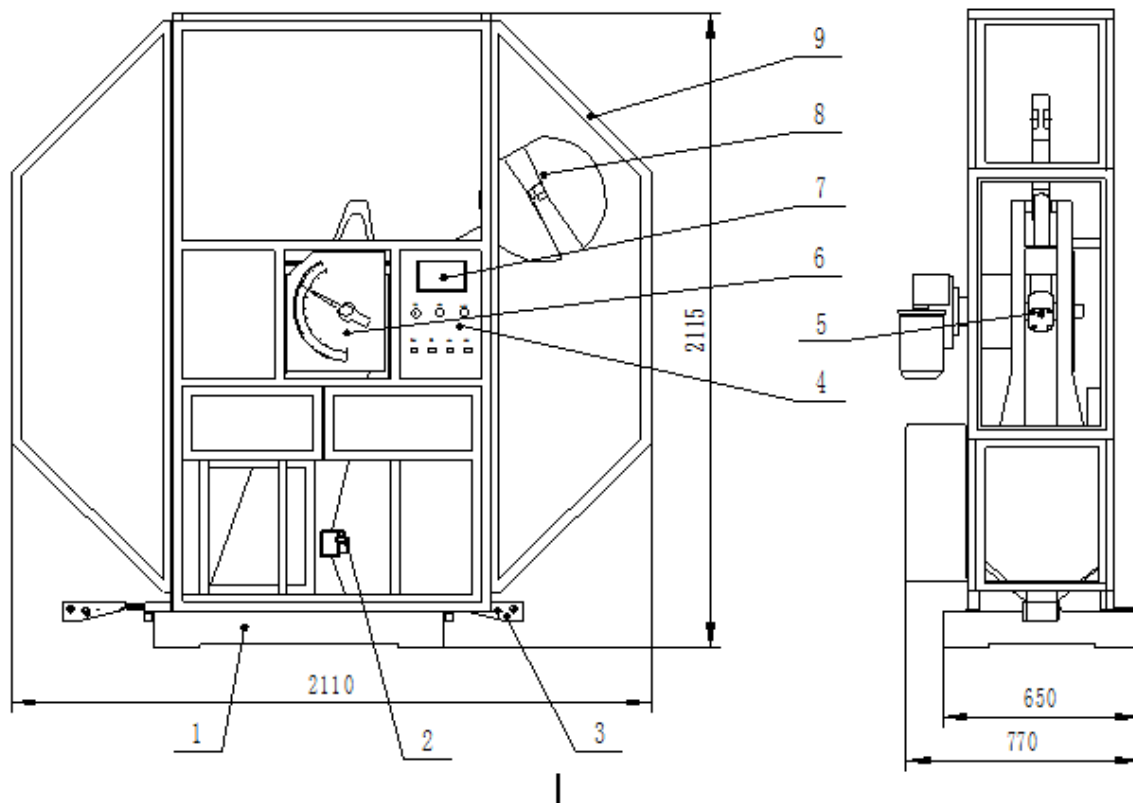

- |                              |                                |
|------------------------------|--------------------------------|
| 1 Framework                  | 2 Specimen supports and anvils |
| 3 Specimen collection device | 4 Control panel                |
| 5 Pendulum                   | 6 Analogue display             |
| 7 Touch screen               | 8 Striker                      |
| 9 Protection shield          |                                |

### Framework

The framework is processed with one body casting. Front and rear columns are symmetric with single beam support axis, with high stiffness and precision.

The framework is made from ductile cast iron with high strength and stiffness, and with good capability of vibration absorbing.

The seat mass is 822kg, 15 times than 750J pendulum mass (54.65), fully complying with standards that seat mass must be 12 times than pendulum mass.

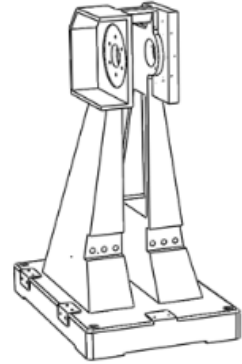

### Pendulum

Pendulum is designed with 3D CAD software, greatly ensuring the striking center accuracy and pendulum moment precision. High strength pendulum rod highly reduces vibration after impact.

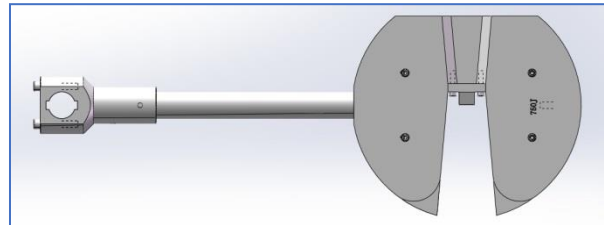

Striking head is combined design. 300J plus two counter weights becomes 450J, and 600J plus two counter weights becomes 750J. It is convenient to perform different energy tests with frequent changing pendulums.

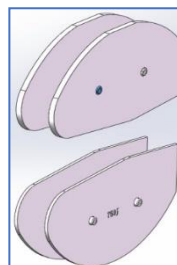
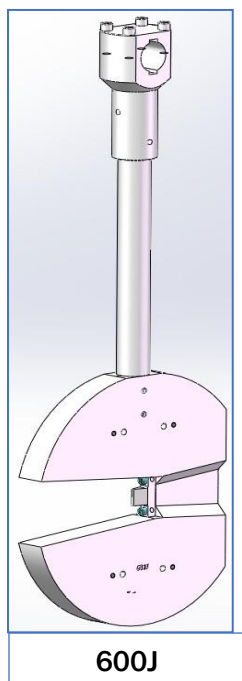

**Counter**

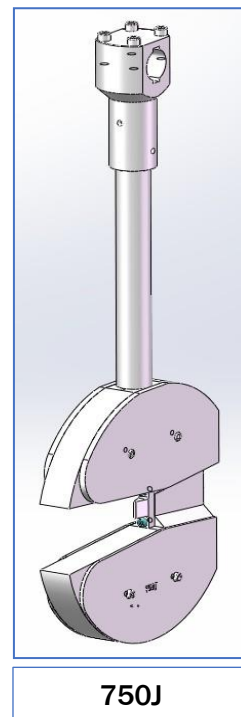

Striking knife is tightened by wedge block, simple to change. Striking knife is available with R2 and R8, fully complying with ASTM, JIS, DIN, GB, ISO, EN and other standards.

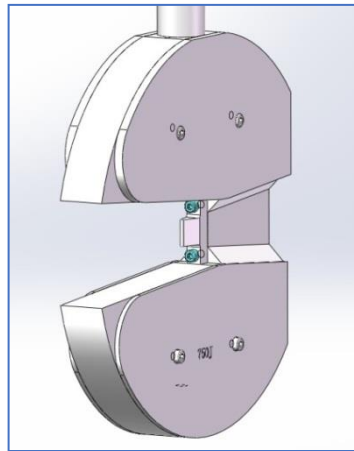
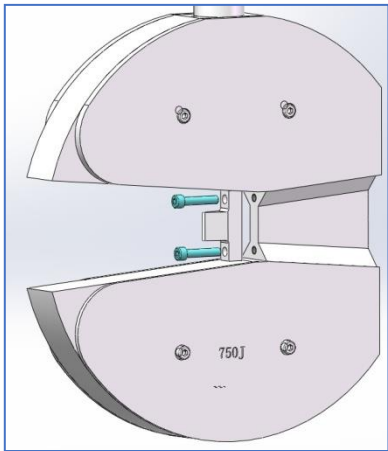

Change striker knife

Striking knife is made of anti-wearing high speed tool steel with hardening treatment, and hardness is larger than HRC60, with high strength, ductility and abrasion resistance.

### Supports and Anvils

Anvil shape is rhombus and can be used in any direction, meaning the using life is 4 times than traditional anvil.

The anvil material is high speed tooling steel CW6Mo5Cr4V2 after hardening treatment, and the hardness is larger than HRC60, with high strength, ductility and abrasion resistance.

It is very simple to change anvils with inner hexagon spanner. The anvil is machined by special process with high precision and good interchangeability.

Anvil is exchangeable and can be used four times by changing mount directions, greatly improving the servicing life and saving cost.

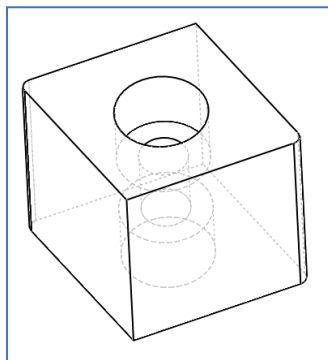

Exchangeable anvil

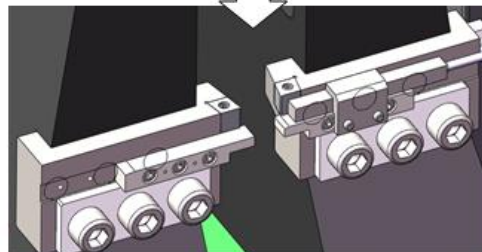
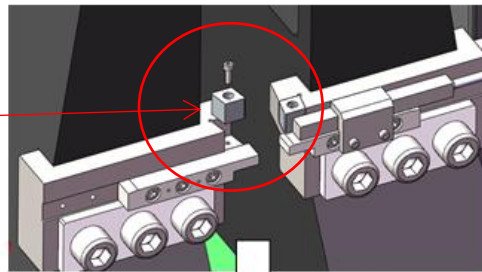

## Energy Display System

Three types of energy display are available:

- Analogue display: simple and direct to read impact energy
- Wide view touch screen
- Computer with test software



Analogue display

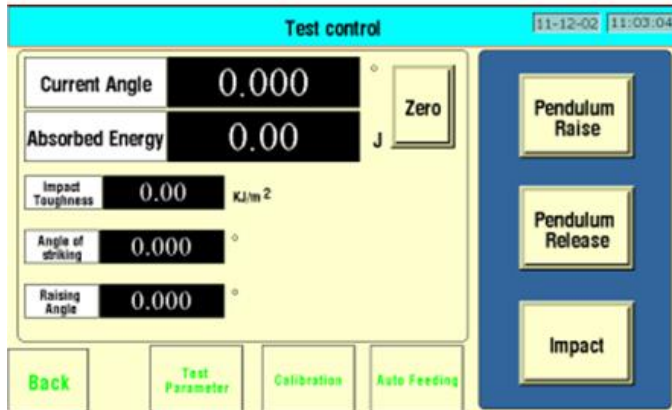

Wide view touch screen

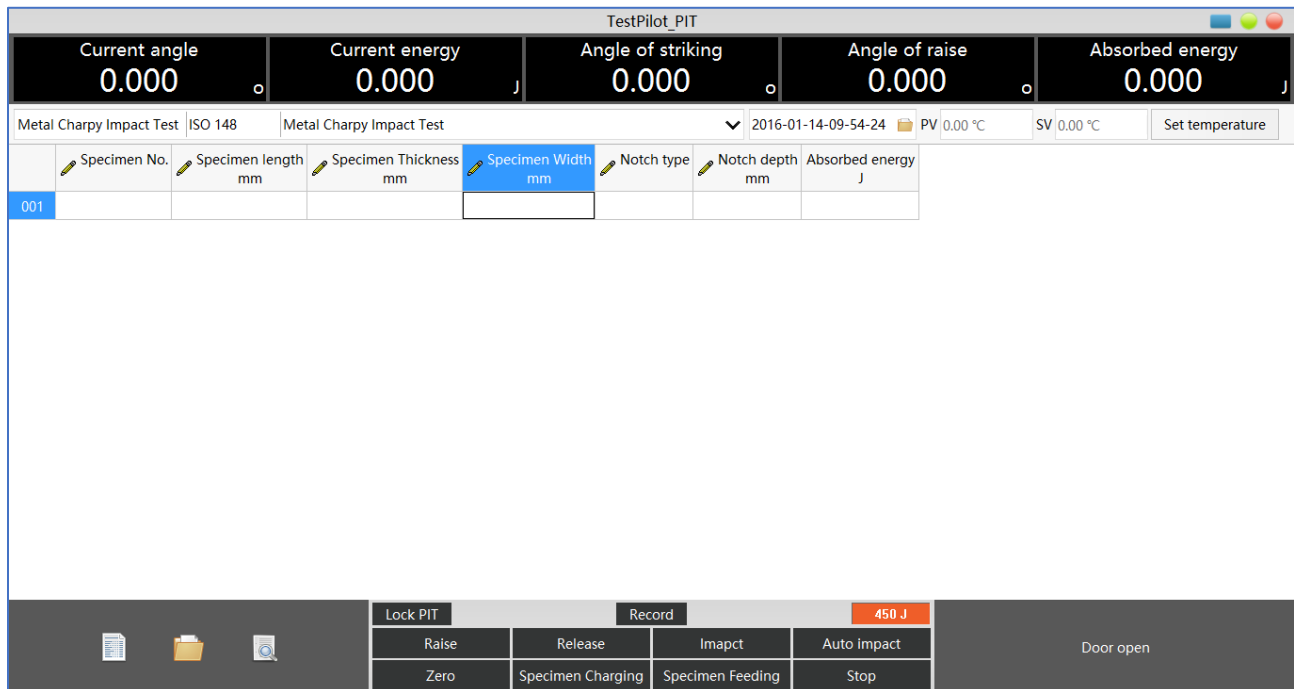

Professional test software

## Specimen Collection System

- Motorized device is used for collecting broken specimens after impact, instead of manual cleaning, which fully prevents striker from getting stuck
- Unique specimen filtering function: automatically judge and transport qualified and unqualified specimens to different collecting box

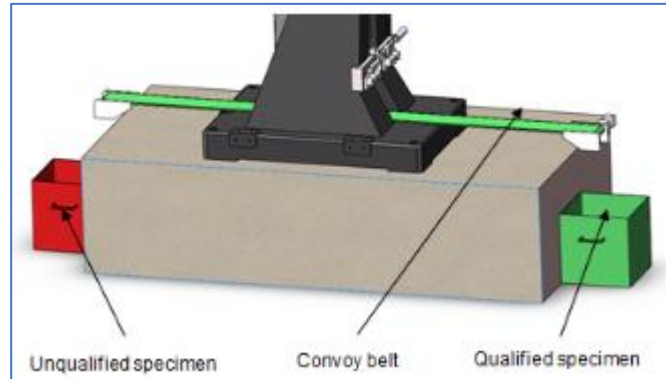

## Safety System

This series of machine has fully closed protection shield to protect operator against specimen splitting during test, and to deny any access to the inside during test. Built-in door interlock further ensures operator safety. The protection shield is constructed with aluminum alloy profile for frame and fiber glass for easy observation. Split-type door design is simple to repair and change pendulum.

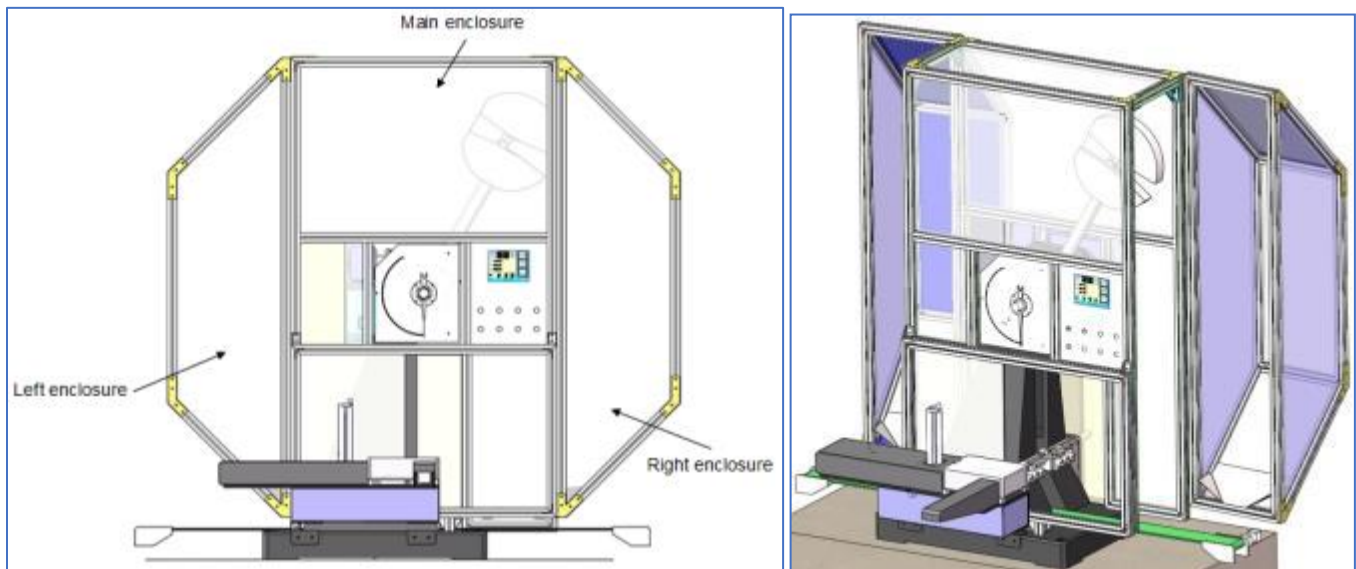

## Specifications for Main Machine

Name		Description
<b>Model No.</b>		Class H
<b>Maximum impact energy</b>		300J, 450J, 600J, 750J
<b>Angle resolution</b>		0.025°
<b>Distance from the axis of support to the center of percussion</b>		750mm
<b>Velocity of striking</b>		5.24m/s
<b>Anvil</b>	Span	40mm
	Radius of curvature of supports	1mm
	Angle of taper of supports	11°±1°
<b>Instrumented striking knife</b>	Radius of striking edge	2mm(R2) or 8mm(R8)
	Angle of striking tip	30°
	Thickness of striker	16mm
<b>Dimension (with protection shield)</b>		77.15 x 26.77 x 78.75 – inches 196 x 68 x 200 cm
<b>Weight</b>		1764lbs 800kg
<b>Power supply</b>		220V±10% 50Hz 5A

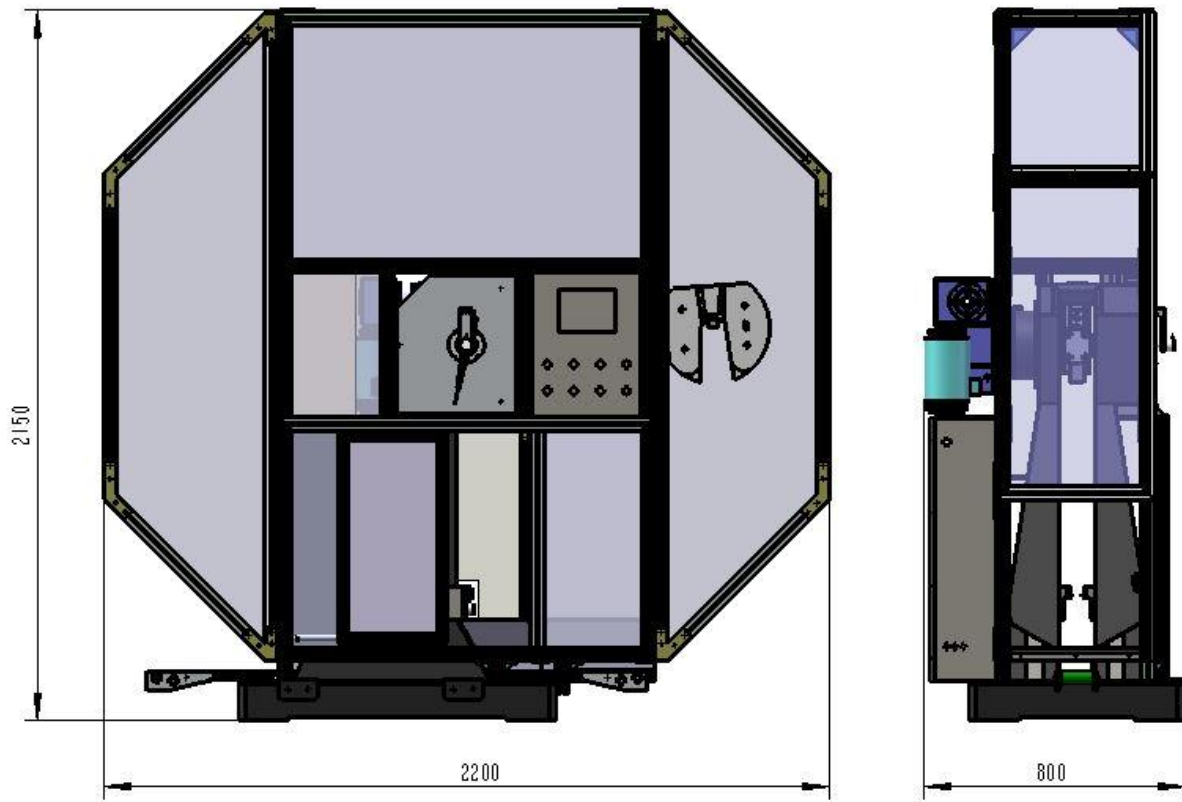

## Standard Configurations

Name	Description	Model		
		752H-2	752H-3	752H-4
Framework	Frame	√	√	√
	Pendulum lock/release system	√	√	√
	Driving system	√	√	√
	Dual clutch system	√	√	√
	Angle measurement system	√	√	√
	SIMENS PLC control	√	√	√
	Analogue display	√	√	√
	Touch screen	√	√	√
	Protection shield	√	√	√
	Other auxiliary parts	√	√	√
	Other auxiliary parts	√	√	√
Servo motor		√	√	√
Instrumented impact system	Data sampling card Data Conditioner Instrumented test software			√
Accessories	Span adjusting device specimen center alignment device inside-hexagonal spanner foundation bolts wedge-shaped irons	√	√	√
Specimen support & anvil	Comply with ISO and ASTM	√	√	√

## Optional Pendulums

Name	Description
Charpy pendulum Please specify ISO striker or ASTM striker	300J
	450J
	600J
	750J

### Note:

- 1) 450J pendulum is assembled by 300J pendulum with two counter weight.
- 2) 750J pendulum is assembled by 600J pendulum with two counter weight.

## Optional Instrumented Pendulums

Name	Description
Instrumented Charpy pendulum & specimen support (striking knife with 30kN force transducer: R2/R8) Please specify ISO striker or ASTM striker	300J
	450J
	600J
	750J

### Note:

- 1) 450J pendulum is assembled by 300J pendulum with two counter weight.
- 2) 750J pendulum is assembled by 600J pendulum with two counter weight.

## Optional Notch Broacher

Name	MODEL	Specifications
Notch Making Machine	GenNotch 4000	V2 and U5 notch Comply with ISO148 and ASTM E23

## Optional Configurations:

Name	Model	Description	Accessories
Automatic cooling and feeding system	LTC601A-2	-60°C-ambient Cooling method: compressor	Specimen auto-feeding system Low temperature chamber Compressor Air pump
	LTC102B-2	-100°C-ambient Cooling method: liquid nitrogen	Specimen auto-feeding system Low temperature chamber
	LTC182B-2	-180°C-ambient Cooling method: liquid nitrogen	Liquid nitrogen cylinder Air pump
Manual cooling system	CDW-60-05	-60°C-ambient Cooling method: compressor	Low temperature chamber Compressor
	CDW-80-05	-80°C-ambient Cooling method: compressor	Low temperature chamber Compressor