



Shoulder Fixtures for Pull-Off and Component Testing

Precision Shoulder Grips for Tensile Testing on NG-EML and SHM Series UTMs

NextGen's shoulder fixtures are specialized tensile grips designed to accommodate specimens with shoulder geometries. These fixtures are critical for standardized testing in accordance with ISO and ASTM protocols where alignment, clamping precision, and repeatability are essential. Compatible with NG-EML and SHM UTMs, these fixtures ensure high-reliability results in both R&D and production environments.

- ASTM D638 (Tensile Properties of Plastics)
- ISO 527 (Tensile Testing of Plastics)
- GB/T 1040 (Plastic Tensile Test Methods)

Applications range across polymer composites, machined plastic components, and metals formed to shoulder profiles. All models support safe and rigid clamping under increasing loads.

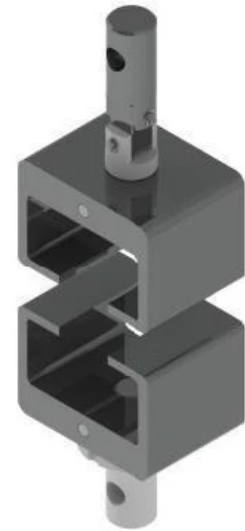

[GET A QUOTE](#)



NGB203A – Tension Grip

The **NGB203A Tension Grip** is designed for low-force tensile testing of cement mortar specimens. With a load capacity of up to 2 kN, this fixture is ideal for evaluating the tensile strength of brittle, cement-based materials. It features a compact yet durable design, Ø10 mm pin connections, and is suitable for use with universal testing machines in ambient environments. The precision alignment and reliable clamping surface ensure accurate and repeatable results in material strength verification.

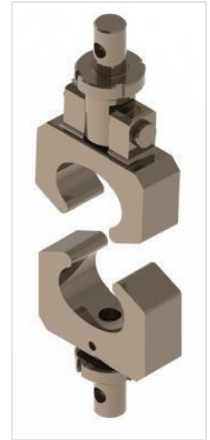

- **Application:** Tension tests for cement mortar.
- **Maximum Capacity:** Up to 2 kN load.
- **Connection:** Ø10 mm pin (upper and lower), compatible with standard UTMs.
- **Height:** 120 mm (upper grip), 88 mm (lower grip).
- **Width:** 88 mm.
- **Grip Weight:** 1.18 kg (upper grip), 1.0 kg (lower grip).
- **Working Temperature:** Ambient.

Technical Specifications – NGB203A Tension Grip for Cement Mortar

Parameter	Specification
Application	Tension test for cement mortar
Maximum Force Capacity	≤ 2 kN
Upper Grip Weight	1.18 kg
Lower Grip Weight	1.0 kg
Working Temperature	Ambient



Parameter	Specification
Connection Type	Ø10 mm pin (upper and lower)
Upper Grip Height (A)	120 mm
Lower Grip Height (B)	88 mm
Width (C)	88 mm



NGC103A – Tension Grip

The **NGC103A Tension Grip** is purpose-built for low-force adhesive tensile testing. With a force capacity of up to 1kN, it is ideal for evaluating adhesive bond strength between substrates under controlled laboratory conditions. This compact fixture features a shoulder clamping mode and is designed for substrates measuring 50 × 50 mm and adhesives up to 12 mm thick. Standard Ø10 mm pin connections and stable construction make NGC103A a reliable choice for quality control and material development labs.

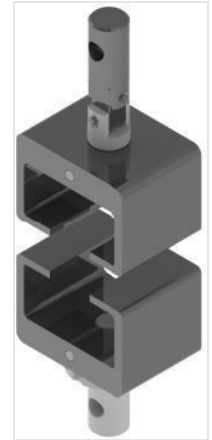

- **Application:** Tension tests for adhesives and bonded materials.
- **Maximum Capacity:** Up to 1 kN load.
- **Connection:** Ø10 mm pin (upper and lower), compatible with most universal testing machines.
- **Height:** 100 mm (upper grip), 80 mm (lower grip).
- **Width:** 70 mm.
- **Grip Weight:** 0.75 kg (upper grip), 0.8 kg (lower grip).
- **Clamping Mode:** Shoulder.
- **Specimen Size:** Substrate: 50 × 50 mm; Adhesive: 50 × 12 mm.
- **Working Temperature:** Ambient.

Technical Specifications – NGC103A Tension Grip for Adhesive Testing

Parameter	Specification
Application	Tension test for adhesives
Maximum Force Capacity	≤ 1 kN
Upper Grip Weight	0.75 kg



Parameter	Specification
Lower Grip Weight	0.8 kg
Working Temperature	Ambient
Connection Type	Ø10 mm pin (upper and lower)
Upper Grip Height (A)	100 mm
Lower Grip Height (B)	80 mm
Width (C)	70 mm
Clamping Mode	Shoulder
Specimen Size	Substrate: 50 × 50 mm Adhesive: 50 × 12 mm



NGC103B – Tension Grip

The **NGC103B Tension Grip** is optimized for adhesive tensile testing where larger substrates or longer bonded joints are involved. With a 1kN maximum load capacity and a shoulder clamping mechanism, it ensures stable and precise specimen alignment during testing. Designed for substrates up to 75 mm long and adhesives 12 mm thick, this fixture is well-suited for laboratories performing repeatable adhesive strength evaluations. Standard $\varnothing 10$ mm pin compatibility makes it ideal for use with most tabletop universal testing systems.

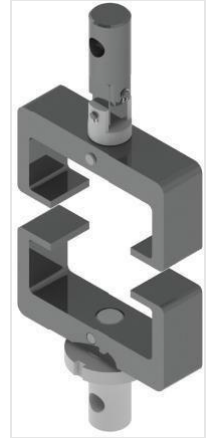

- **Application:** Tension tests for adhesives and bonded assemblies.
- **Maximum Capacity:** Up to 1 kN load.
- **Connection:** $\varnothing 10$ mm pin (upper and lower), standard UTM compatible.
- **Height:** 110 mm (upper grip), 80 mm (lower grip).
- **Width:** 95 mm.
- **Grip Weight:** 0.5 kg (upper grip), 0.6 kg (lower grip).
- **Clamping Mode:** Shoulder.
- **Specimen Size:** Substrate: 75 × 12 mm; Adhesive: 50 × 12 mm.
- **Working Temperature:** Ambient.

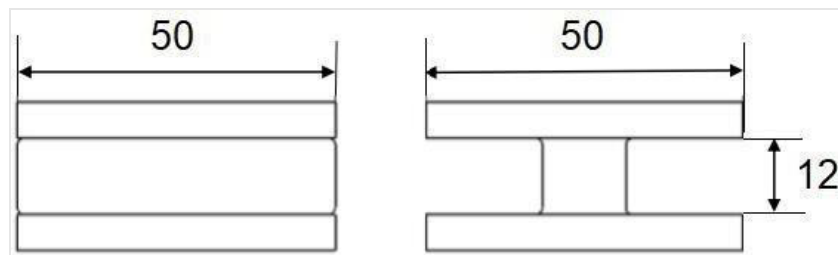



Technical Specifications – NGC103B Tension Grip for Adhesive Testing

Parameter	Specification
Application	Tension test for adhesives
Maximum Force Capacity	≤ 1 kN
Upper Grip Weight	0.5 kg
Lower Grip Weight	0.6 kg
Working Temperature	Ambient
Connection Type	Ø10 mm pin (upper and lower)
Upper Grip Height (A)	110 mm
Lower Grip Height (B)	80 mm
Width (C)	95 mm
Clamping Mode	Shoulder
Specimen Size	Substrate: 75 × 12 mm Adhesive: 50 × 12 mm



NGC203 – Tension Grip Series

The **NGC203 Tension Grip Series** is developed for adhesive strength testing across a wide range of specimen sizes. Available in three models—**NGC203B**, **NGC203C**, and **NGC203E**—this series supports test blocks from 50×50 mm to 200×200 mm, all within a 2 kN maximum force range. These grips feature a modular design that allows the number of bonding blocks to be tailored to specific testing requirements. Constructed for reliability and repeatability in ambient conditions, all models are equipped with Ø10 mm pin connections and standardized dimensions for integration with universal testing systems.

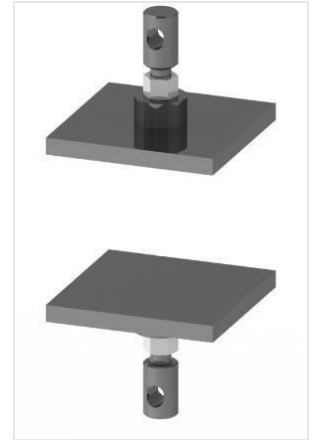

- **Application:** Tension tests for adhesive strength.
- **Models:** NGC203B, NGC203C, NGC203E.
- **Maximum Capacity:** Up to 2 kN load.
- **Specimen Sizes:** 50 × 50 mm (B), 100 × 100 mm (C), 200 × 200 mm (E).
- **Connection:** Ø10 mm pin (upper and lower), compatible with standard UTMs.
- **Height:** 60 mm (both upper and lower grips).
- **Widths:** 50 mm (B), 100 mm (C), 200 mm (E).
- **Grip Weight:** See model-specific table below.
- **Working Temperature:** Ambient.
- **Note:** The number of bonding blocks can be customized based on client requirements.

Technical Specifications – NGC203 Tension Grip Series for Adhesive Strength Testing

Model	NGC203B	NGC203C	NGC203E
Specimen Size	50 mm × 50 mm	100 mm × 100 mm	200 mm × 200 mm
Maximum Force	≤ 2 kN	≤ 2 kN	≤ 2 kN



Model	NGC203B	NGC203C	NGC203E
Upper Grip Weight	0.36 kg	0.95 kg	3.32 kg
Lower Grip Weight	0.36 kg	0.95 kg	3.32 kg
Working Temp.	Ambient		
Connection	Ø10 mm pin (upper and lower)		
Upper Grip Height (A)	60 mm	60 mm	60 mm
Lower Grip Height (B)	60 mm	60 mm	60 mm
Width (C)	50 mm	100 mm	200 mm
Bonding Block Count	Customizable per client request		



NGC503A – Tension Grip

The **NGC503A Tension Grip** is a compact fixture designed for precise adhesive strength testing under moderate tensile loads. Supporting forces up to 5 kN, this grip is ideal for small-scale bonded specimens, such as those with substrate dimensions of 70 × 70 mm and adhesive layers of 40 × 40 mm. The grip features a shoulder-type clamping mechanism for secure and repeatable alignment during testing. Its lightweight construction and Ø10 mm pin compatibility make it suitable for most tabletop universal testing machines operating in ambient environments.



- **Application:** Tension test for adhesives and bonding strength validation.
- **Maximum Capacity:** Up to 5 kN load.
- **Connection:** Ø10 mm pin (upper and lower), UTM-compatible.
- **Height:** 45 mm (upper grip), 60 mm (lower grip).
- **Width:** 90 mm.
- **Grip Weight:** 0.03 kg (upper grip), 0.16 kg (lower grip).
- **Clamping Mode:** Shoulder.
- **Specimen Size:** Substrate: 70 × 70 mm; Adhesive: 40 × 40 mm.
- **Working Temperature:** Ambient.

Technical Specifications – NGC503A Tension Grip for Adhesive Testing

Parameter	Specification
Application	Tension test for adhesives
Maximum Force Capacity	≤ 5 kN
Upper Grip Weight	0.03 kg



Parameter	Specification
Lower Grip Weight	0.16 kg
Working Temperature	Ambient
Connection Type	Ø10 mm pin (upper and lower)
Upper Grip Height (A)	45 mm
Lower Grip Height (B)	60 mm
Width (C)	90 mm
Clamping Mode	Shoulder
Specimen Size	Substrate: 70 × 70 mm Adhesive: 40 × 40 mm

NextGen’s shoulder grip solutions are crafted for high-performance tensile testing where shoulder-type samples are standard. Their modular compatibility with NG-EML and SHM UTM machines ensures maximum utility across labs and testing departments. Contact us today to discuss your testing needs or to request a formal quotation for these fixtures.

[GET A QUOTE](#)