



HDT/VICAT Testing Machine – Thermal Analysis for Plastics NG-HDT

Standards: [ISO 2507](#), [ISO 75](#), [ISO 306](#), [ASTM D648](#), [ASTM D1525](#), [GB/T 8802](#), [GB/T 1633](#), [GB/T 1634](#)



ULTIMATE USER-FRIENDLINESS



LEADING DEPENDABILITY AND RELIABILITY



STRICT COMPLIANCE WITH INDUSTRY STANDARDS



STOCKED CONSUMABLES AND SPARES



TRUSTED AFTER SALES TECHNICAL SUPPORT



LIFETIME PRODUCT SUPPORT ADVANTAGE

Description

The **NG-HDT HDT/Vicat testing machine** is designed to measure heat deflection temperature under load (HDT) and Vicat softening temperature (VST) for thermoplastics, including pipes and fittings. It runs these methods under a constant load with a controlled linear heating rate, which fits routine QA/QC work and material development.

The platform is offered in 3-station and 6-station configurations and uses a built-in touchscreen industrial PC to run the test sequence from loading and measurement through unloading and cooling. Measurement is based on Class A temperature sensing and LVDT displacement measurement, with an oil bath rated up to 300°C. The bath design includes turbulence suppression and cyclic heating functions to support steady heating conditions during the ramp.

Test data can be reviewed and exported over Ethernet. The system can also be paired with options such as a chiller for faster cooldown and an external oil-vapor extraction and filtration unit for high-temperature operation.



[GET A QUOTE](#)



Materials and Specimen Types This Machine Supports

This system is used for thermoplastic materials, including plastic pipes and fittings, where HDT and Vicat (VST) values are part of product qualification, incoming inspection, or material comparison work. It supports both test types on the same platform, so labs can cover common thermal performance checks without switching equipment.

Supported Specimen Sizes

For Vicat (VST), the maximum specimen size is 50 × 16 × 6.5 mm. For HDT, the maximum specimen size is 130 × 15 × 13 mm. A long-span option is available for ISO 75-3 / GB/T 1634.3 methods and supports specimens up to 260 × 15 × 13 mm, with a maximum span of 210 mm.



Watch Video



Watch the HDT/VICAT Testing Machine – Thermal Analysis for Plastics NG-HDT product video.

[WATCH ON YOUTUBE](#)



Standards and Test Methods You Can Run (ISO / ASTM / GB/T)

NG-HDT supports a broad set of HDT and Vicat (VST) methods used in plastics testing, including the most commonly referenced standards in North America and internationally, such as the ones listed below:



- **ASTM D648: Standard Test Method for Deflection Temperature of Plastics Under Flexural Load in the Edgewise Position** - North American reference method for HDT. Used to compare how plastics deform under a specified flexural stress while temperature increases.
- **ASTM D1525: Standard Test Method for Vicat Softening Temperature of Plastics** - North American reference method for VST. Measures the temperature at which a specified needle penetration occurs under defined load and heating conditions.
- **ISO 75-1: Plastics - Determination of temperature of deflection under load - Part 1: General test method** - The general ISO framework for HDT style testing, including the overall procedure and common test setup.
- **ISO 75-2: Plastics - Determination of temperature of deflection under load - Part 2: Plastics and ebonite** - The commonly used ISO part for most plastics, defining standard condition sets (including the A/B/C stress conditions).
- **ISO 75-3: Plastics - Determination of temperature of deflection under load - Part 3: High-strength thermosetting laminates and long-fibre-reinforced plastics** - Used when the material category and setup fall under high-strength laminates or long-fibre reinforced plastics.



- **ISO 306: Plastics - Thermoplastic materials - Determination of Vicat softening temperature (VST)** - The ISO Vicat method, including the standard A50/B50/A120/B120 condition sets (load and heating rate combinations).
- **ISO 2507 (series): Thermoplastics pipes and fittings - Vicat softening temperature** - Vicat test method and conditions written specifically for pipe and fitting samples. (Often referenced alongside ISO 306 when the product is pipe-based.)
- **GB/T 1634.1: Plastics - Determination of temperature of deflection under load - Part 1: General test method** - Adoption aligned to the ISO 75-1 structure for HDT style testing.
- **GB/T 1634.2: Plastics - Determination of Temperature of Deflection under Load - Part 2: Plastics, Ebonite and Long-fibre-reinforced Composites** - Adoption aligned to ISO 75-2 for standard DTUL/HDT condition sets.
- **GB/T 1634.3: Plastics - Determination of temperature of deflection under load - Part 3: High-strength thermosetting laminates** - Part focused on high-strength thermosetting laminates (paired conceptually with ISO 75-3 use cases).
- **GB/T 1633: Plastics - Thermoplastic materials - Determination of Vicat softening temperature (VST)** - Vicat method aligned to the same test concept as ISO 306 / ASTM D1525 (needle penetration under controlled conditions).
- **GB/T 8802: Thermoplastics pipes and fitting - Determination of vicat softening temperature** - Vicat method written for thermoplastic pipes and fittings (pipe QC and product qualification use).



Automated Test Sequence: Loading, Heating, Measurement, Unloading, Cooling

NG-HDT is built around a hands-off test sequence that follows the same order labs run every day: bring the bath to the starting condition, apply the required load, ramp temperature at the selected rate, record displacement or penetration, then unload and cool down. For HDT, the setup uses the support span and loading nose to track deflection under flexural stress. For Vicat, the needle applies the specified load and the system tracks penetration as temperature increases. Once a run is complete, the unit moves into the cooling step so the next test can be set up.



Preset Standards + Custom Methods (Touchscreen Control)

The built-in touchscreen industrial PC lets operators select preset methods based on common ISO, ASTM, and GB/T standards, or create custom methods when a lab needs a specific combination of load and heating rate. During operation, the system monitors key checks at startup such as oil level, sensor status, and door-lock state, and it assumes control of the run without manual step-by-step intervention. Test data can be saved for later review, searched as history, and exported over Ethernet when the unit is connected to a network.



Class A Temperature Sensing + LVDT Displacement Measurement

NG-HDT uses a Class A PT100 temperature sensor package and an LVDT displacement sensor system to capture the two signals that define HDT and Vicat testing: bath temperature and specimen movement. Temperature control is tied to the oil-bath layout and control parameters so the bath stays uniform during the ramp, while the displacement system tracks deflection or penetration without relying on operator interpretation.

Key displacement specs:

- Displacement resolution: **0.001 mm**
- Displacement accuracy: **better than 0.01 mm**
- Displacement measurement range: **15 mm**

Cooling Options and Oil-Consumption Reduction

NG-HDT uses an immersion oil bath and supports water cooling as the standard cooling method. For labs that need shorter turnaround between runs, the system can be configured with an external chiller to speed up cooldown after a test. The platform also supports optional nitrogen protection on the oil surface, which helps reduce silicone oil consumption over time in higher-temperature, high-usage workflows.

With a chiller installed, typical cooling time is 45 minutes from 200°C down to 23°C.



Safety Systems That Prevent Overheat, Spills, and Damage

NG-HDT is designed around a closed test chamber that separates operators from the hot oil bath during a run. The protective shield stays closed for testing, and the door is locked while the program is active to reduce the chance of accidental contact or splashing. The system also checks basic conditions at startup, including oil level, sensor status, and door-lock state, and flags abnormal conditions before the test proceeds.

Closed Shield + Auto Door Lock During Testing

A fully enclosed protection shield is used for testing, and the chamber door locks automatically during operation.

Overheat Cut-Off + Oil Level Monitoring + Overflow Protection

The unit includes dual overtemperature protection that cuts heating and triggers an alarm if limits are exceeded. Oil level monitoring works with an overflow port and automatic stop logic to prevent heater damage when the oil level is low and to handle overflow conditions during use.



Designed for Fast Cleaning and Easy Calibration

The test area is set up for routine lab maintenance, with a modular specimen rack that can be removed without tools. This makes it easier to clear fragments if a specimen drops and to keep the chamber clean between runs. The open-type oil tank uses quick-release knobs and can be cleaned in about five minutes. A dedicated calibration interface is built in to support quick checks with an external thermometer, without improvised setups.



To protect contact parts during day-to-day handling, the Vicat needle is kept suspended when not in use, and separating pliers are included to help remove specimens without damaging the needle or pin.



Models and Technical Specifications

In the table below, you'll find the available model configurations and the full technical specifications for the NG-HDT HDT/Vicat testing machine, including key performance parameters, supported test setups, utilities, and dimensions.

Specification	NG-HDT300	NG-HDT600
Test stations	3	6
Temperature range	Ambient to 300 °C (572 °F)	
Heating rate	120 ± 10 °C/h (216 ± 18 °F/h) 50 ± 5 °C/h (90 ± 9 °F/h)	
Displacement resolution	0.001 mm	
Displacement accuracy	Better than 0.01 mm	
Displacement measurement range	15 mm	
HDT test span	2.52 in (64 mm) (GB/T 1634.2, ISO 75-2) 3.94 in (100 mm), 4.00 in (101.6 mm) (ASTM D648, optional)	
HDT stress	1.80 MPa, 0.45 MPa, 8.00 MPa (GB/T 1634.2) 0.455 MPa, 1.82 MPa (ASTM D648) Custom (GB/T 1634.3, ISO 75-3)	
VST load	10 ± 0.2 N, 50 ± 1.0 N	
VST maximum specimen size	1.97 x 0.63 x 0.26 in (50 x 16 x 6.5 mm)	
HDT maximum specimen size	5.12 x 0.59 x 0.51 in (130 x 15 x 13 mm) 9.06 x 0.50 x 0.28 in (230 x 12.8 x 7 mm) (optional for GB/T 1634.3, ISO 75-3)	



Specification	NG-HDT300	NG-HDT600
Bath volume	18 L	
Temperature sensor	PT100	
Cooling time	45 min (200 °C to 23 °C / 392 °F to 73 °F) with chiller	
Cooling method	Water cooling	
Loading type	Electric	
Communication port	LAN + 2 x USB 2.0	
Power consumption	3.5 kW	
Power supply	1-phase, 220 V AC ± 10%, 50 Hz ± 2%	
Weight	353 lb (160 kg)	
Dimensions	50.4 x 20.9 x 31.5 in (1280 x 530 x 800 mm) (L x W x H)	50.4 x 24.4 x 49.6 in (1280 x 620 x 1260 mm) (L x W (door open) x H (door open))

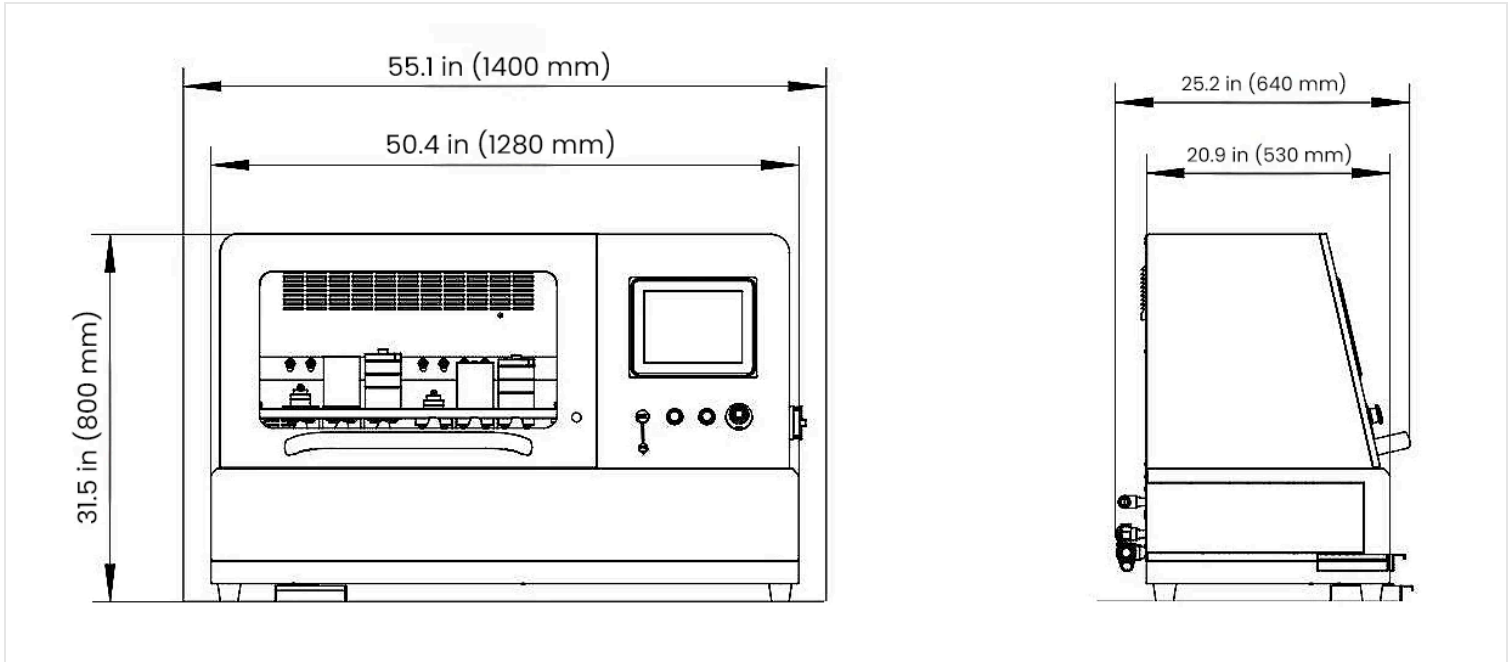

Standard Configuration and Optional Accessories

Below is an overview of what ships with the NG-HDT system as standard, plus the optional add-ons that can be supplied based on your lab setup. Quantities for station-specific items differ between the 3-station and 6-station configurations.

Standard Configuration

This table lists the components supplied with the system. Items marked 3/6, 4/7, etc. depend on whether the unit is configured with 3 or 6 test stations.

Name	Description	QTY
Test stations		3/6



Name	Description	QTY
Support span	2.52 in (64 mm) (ISO 75) 4.00 in (101.6 mm) (ASTM D648, Method A) 3.94 in (100 mm) (ASTM D648, Method B)	3/6
Immersion bath		1
Temperature sensor	PT100, Class A	4/7
Displacement sensor		3/6
Computer	Built-in 10.4" industrial PC, capacitive touch screen	1
HDT loading nose	R = 0.12 in (3.0 ± 0.2 mm)	3/6
VST needle	Cross-section area 1.000 mm ² ± 0.015 mm ²	3/6
Universal weight set	Combined load up to 12.1 lb (5500 g). All loads from 1 g to 5500 g are possible in 1 g steps.	3/6
Test software	GenTest, English version	1
Test accessories	Tweezers, specimen scissors, specimen separating pliers, specimen box, wrenches (1.5 mm and 2.5 mm), oil filling funnel, inlet and outlet water pipes (rated to 300 °C / 572 °F), 78.7 in (2 m) length	1



Name	Description	QTY
Calibration accessories	Gauge blocks (2 mm, 3 mm, 2 x 4 mm) Temperature calibration hole (ϕ 3.2 mm)	1
Quality certificate		1
Operation manual	USB drive	1





NEXTGEN
MATERIAL TESTING

YOUR QUALITY TESTING CHOICE

Have Questions or Need to Confirm a Detail?

If you're not sure which method you need to run, what station count fits your workload, or whether you need options like a chiller or oil-vapor purifier, send us a [quick request online](#). Share your material type, applicable standard (ISO/ASTM), and specimen size, and we'll get back to you as soon as possible with clear answers and the right configuration for your lab.

[GET A QUOTE](#)

NORTH AMERICA (CORPORATE HEADQUARTERS): 170-422 Richards St., Vancouver, BC, V6B 2Z4 Canada

CALIFORNIA: 3503 Jack Northrop Ave., Suite # AF937, Hawthorne, CA 90250

Toll Free: +1 (888) 332-3582 | Fax: +1 905 247-0555 | www.nextgentest.com



Optional Accessories

Optional items can be supplied to match your workflow, cooling requirements, or test method needs.

Name	Description
Universal weight set	Combined load up to 12.1 lb (5500 g). All loads from 1 g to 5500 g are possible in 1 g steps.
Vicat weight set	10 N and 50 N in accordance with ISO 306 and ASTM D1525 (one set required per measuring station)
HDT loading nose	R = 0.12 in (3.0 ± 0.2 mm)
VST needle	Cross-section area 1.000 mm ² ± 0.015 mm ²
Work bench	55.1 x 25.6 x 29.1 in (1400 x 650 x 740 mm)
Chiller	2.2 kW
Oil-vapor purifier	80 W, 3-layer filter, 51.2 in (1.3 m) pipe 16.7 x 9.8 x 16.1 in (425 x 250 x 410 mm)
Filter set (for oil-vapor purifier)	First layer: 5 pcs Second layer: 2 pcs Third layer: 1 pc
Adjustable-span support	Meets GB/T 1634.3 and ISO 75-3 Maximum span: 8.27 in (210 mm) Maximum specimen: 10.24 x 0.59 x 0.51 in (260 x 15 x 13 mm)