



## Fruit Firmness Tester



**ULTIMATE USER-FRIENDLINESS**



**LEADING DEPENDABILITY AND RELIABILITY**



**STRICT COMPLIANCE WITH INDUSTRY STANDARDS**



**STOCKED CONSUMABLES AND SPARES**



**TRUSTED AFTER SALES TECHNICAL SUPPORT**



**LIFETIME PRODUCT SUPPORT ADVANTAGE**

### Description

This German manufactured fruit firmness penetrometer and fruit hardness testing device is designed specification for the determination of the pulp hardness of a given fruit. Additionally, the system is fully capable of testing the firmness of vegetables, meat and even fish thanks to the interchangeable indenters. This state-of-the-art device is invaluable for trading companies serious about their quality control procedures. This fruit texture analyzer helps identify the harvest date of the specific fruits relative to the time of transpirations and storage. One of the most valuable features of the ideal replacement for fruit penetrometer system is that it offers a rare non-destructive testing solution for your fruits and vegetables which can save thousands of dollars in inventory.

A unique value of the tester is that it is a non-destructive test method to determine the ripeness of fruit, vegetables and other food products. The fruit hardness tester can be used on the following:



[GET A QUOTE](#)

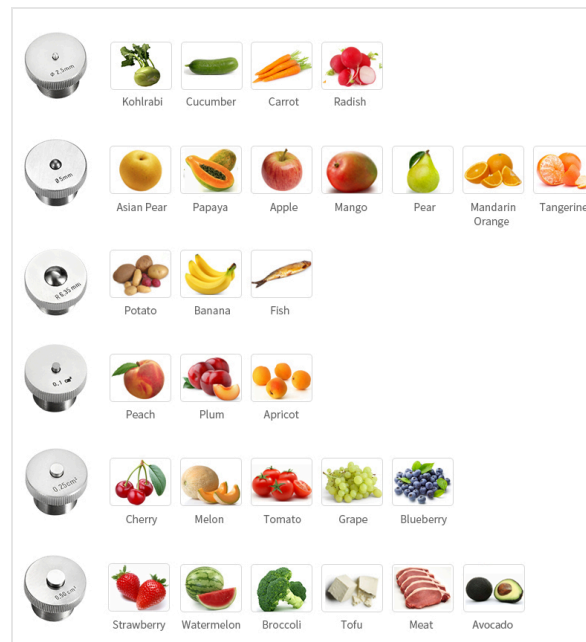

The tester provides important quality control information designed for quality control and price setting benefiting both the seller and the end-user. The system is famous for its ability of using the portable fruit hardness tester for both indoor and outdoor workplace conditions. Our fruit firmness tester is also the optimal solution to replace a vegetable penetrometer.

## System Benefits

- Non destructive testing to preserve inventory
- Highly reproducible and accurate
- Interchangeable test anvils for virtually all types of fruits, vegetables, fish and other products
- Available calibration certification
- Leading instrument for the food industry
- The ideal replacement for fruit penetrometer



## Watch Video



Watch the Fruit Firmness Tester product video.

[WATCH ON YOUTUBE](#)



## Testing Method

When performing a fruit firmness test, the operator measures the opposite sides of each fruit, vegetable or other food products for the purpose of identifying the firmness value on both the sun-side and the shadow-side. By applying a constant pressure on the fruit over a defined measuring time, the system indicates the hardness value of the specific product. The major benefit of this non-destructive test is that the fruit firmness tester does not penetrate the peel of the tested food product.

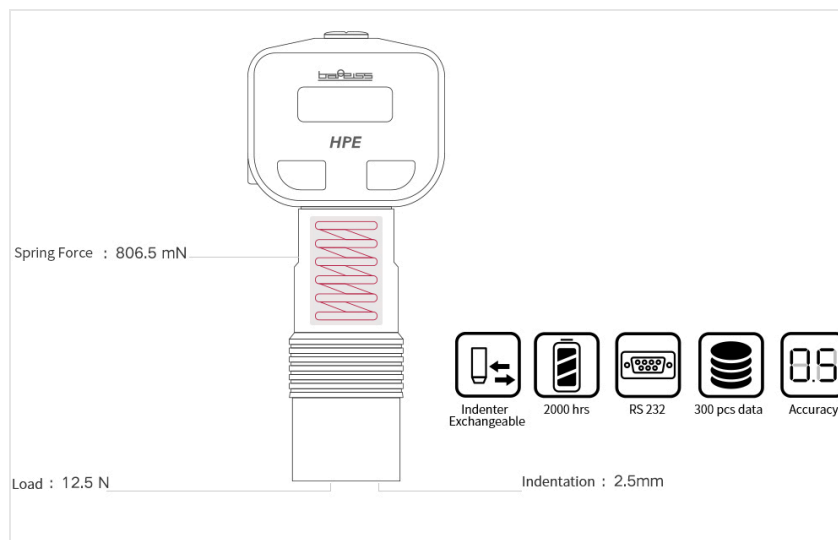

## Standard Configurations

- Fruit firmness tester – main unit
- Designated test anvil
- Charger
- Foam-fitted Case.

**NOTE:** Additional anvils are sold separately.



## Features

- German manufactured
- Ergonomic and portable design
- Interchangeable anvils designed to test fruits, vegetables, meat, and fish
- The optimal solution to replace a vegetable penetrometer
- The system comes standard with 1 anvil with additionally anvils which can be purchased at a later time.

## Anvil Specifications

Indenter Size	Fruit or Vegetable
zyl 0,1 cm <sup>2</sup> (Ø 3,65 mm)	for peaches, apricots and plums
zyl 0,25 cm <sup>2</sup> (Ø 5,63 mm)	for cherries, melons, tomatoes, blueberries, grapes, eggplant
zyl 0,50 cm <sup>2</sup> (Ø 7,98 mm)	or strawberries, water melons, broccoli, meat, tofu
Ø 5,0 mm	ball for avocados, papayas, apples, mangoes, cucumber, pepper, pears, oranges and citrus fruits, onions (soft)
Ø 2,5 mm	ball for kohlrabi, carrots, cucumber, radish, courgette, onion (firm)
radius 6,35 mm	for boiled potatoes, bananas, smoked fish, boiled beetroot



## Technical Specifications

Model	Fruit Firmness Tester
Measuring Range	0-100 Empirical Units for Comparison
Battery Life	200 Hours
Memory	300 Readings
Output	RS232
Dimensions (L x W x H)	7.5 x 2.75 x 1.58" 190 x 70 x 40 mm
Weight	1.3 lbs / 0.6kg



## Accessories

### Calibration Device Check for the HPE ([Fruit Firmness Tester Units](#))

The calibration device is supplied in accordance with ISO 9000 standard. The system is checked for accuracy of Shore hardness testers via spring force control by intervals of ten for the measuring ranges Shore A/B/0/C/D/DO and L, L/c. DIN 53 505, EN ISO 868, NF EN ISO 868, ASTM D2240, JIS K 6253.



Full Scope of Test Anvil for the Fruit Firmness Tester

The unit can be equipped with any one of the following test anvils for your fruit, vegetables, meat and fish firmness testing including:

- 0.1 cm<sup>2</sup> for peaches, apricots and plums
- 0.25 cm<sup>2</sup> for cherries and tomatoes test anvil
- 0.50 cm<sup>2</sup> for strawberries Taster Kugel
- Ø 5 mm for apples and avocados Taster Kugel
- Ø 2.5 mm for carrots, cucumbers, radish, kohlrabi and melons



System Dimensions

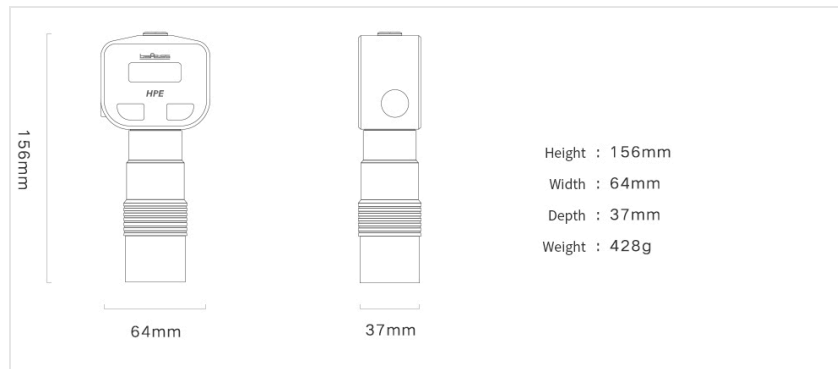

**GET A QUOTE**