



Telebrineller Hardness Testing System - TeleGen

Standard:

ASTM E10

Description

Telebrineller - Measuring Brinell Hardness anywhere in the field, the plant or the laboratory.

A test bar of known BHN (Brinell Hardness Number), approximating the hardness of the specimen to be tested, is selected. Consistent accuracy is maintained when the test bar BHN is within + or -15% of the specimen BHN and is of the same general material. (Testing non-ferrous materials with carbon steel bars causes impact errors that must be compensated for by applying correction factors to the test results.) The test bar is inserted into the Telebrineller instrument and the instrument placed upon the specimen. The Telebrineller instrument is complete with test bar (1), the anvil (2), encased in a soft molded rubber head (3), rests on the test bar. The rubber head and a similar resting block (4), provide non-skid footing. Below the test bar, a steel impression ball (5), secured in the base of the rubber head, is in contact with both the test bar and the specimen. The anvil is struck sharply with a two to five pound hammer. The impact, regardless of force, is transmitted equally to the test bar and, through the impression ball to the specimen metal (6), making impressions in both. The diameters of the resulting impressions are directly related to the respective hardness of the test bar and the specimen. A spacing bar (7), operated by a spring catch and button, adjusts the test bar to a clear area for each test.



Accuracy:

Standard Telebrineller Test Bars are guaranteed to have a uniform hardness within plus or minus 2% of the BHN etched on the end of the bar. They are made of various alloys of carbon steel and finish ground to 9/16" square.

The diameters of the impressions are then measured and converted to Brinell Hardness Numbers using a Brinell manual or automatic microscope. Automated microscopes such as the GenScope are computerized and calibrated systems in which the accuracy is traceable to the National Institute of Standards. The resulting Brinell Hardness Numbers are rounded to the nearest standard BHN occurring at a .05mm interval in Table of ASTM Standard E10 and this BHN is etched on the end of the bar.

Please note the accuracy of any test made with the Telebrineller is dependent upon the relative hardness of the test bar and the test piece. When the Telebrineller is properly used, accuracy of $\pm 5\%$ is consistently attainable, provided that the BHN of the test bar does not differ from the BHN of the test piece by more than 15%.

Test Bars

The test bars which are the core of this system are calibrated to a uniform hardness of $\pm 2\%$ of the labeled BHN. Hardness of the bars is measured by equipment whose accuracy is certified traceable to the National Standards Institute. Readings may be made within .05 millimeters.

Telebrineller Hardness Test Bars (BHN Values)									
627	477	388	321	269	229	194	160	135	114
578	461	375	311	262	223	188	156	131	111
555	444	363	302	255	217	182	151	127	111
534	429	352	293	248	212	176	147	124	109
514	415	341	285	241	207	170	142	121	106
495	401	331	277	235	200	165	138	117	

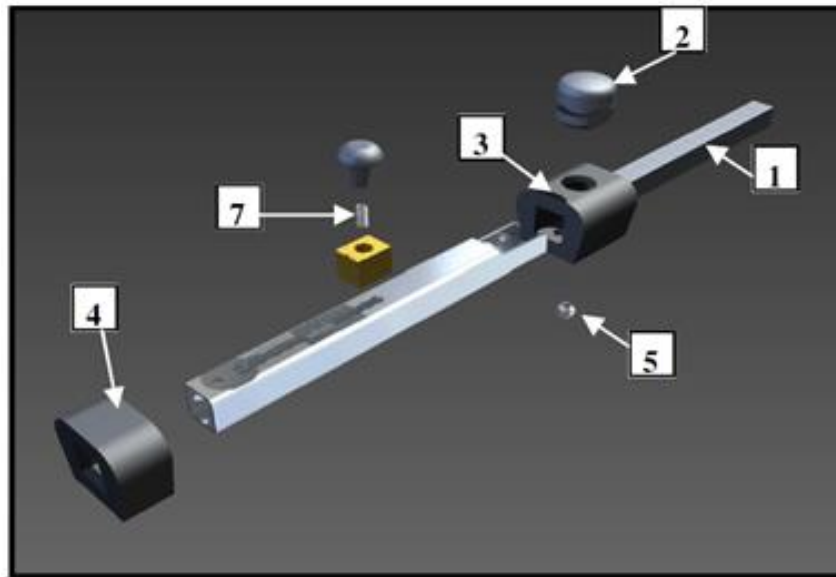

Item #	Description of Part	Part No.
Accessories	Telebrineller Bar Holder Assembly	239-35
1	Anvil	239-17
2	Rubber Front Piece	239-18
3	Test Bar	
4	Impression Ball - Standard	239-14
5	Impression Ball - Tungsten Carbide	239-29
6	Spacer Button	239-19
7	Spacer Block	239-10
8	Spacer Spring	239-12
9	Rubber Rear Piece	239-11
10	Bar Tube	239-16
	Fashlight (LED)	239-37
	Computer	239-34
	Calculation & Record Pad (25 Sheets)	239-33
	Carrying Case	239-20
	Calibration Disk	239-31

Halteman Filletester

The Halteman File tester is designed for the Brinell hardness testing of fillet welds and other hard to reach areas. It is used in conjunction with the Telebrineller. For easier handling, it is recommended that the standard Telebrineller Test Bars be cut in half. Impressions can be measured by using the 5/8" diameter end of the microscope nose piece.



Lead Time

2-5 Business Days Depending on when the PO is placed

Model and Accessories

Model	Description
	<i>Main Unit</i>
TeleGen	Telebrineller Hardness Testing System
	<i>Accessories</i>
NG-STB	Steel Telebrineller Test Bars
NG-ATM	Aluminum Telebrineller Test Bars
NG-TeleCD	Calibration Disc – for Checking Microscope Calibration
NG-Filletester	Halteman Filletester
NG-TeleScope	Microscope – for use with Filletester or Telebrineller
NG-TeleComp	Computer – for Telebrineller set
NG-Bar Holder	Bar Holder

* Request a [formal quotation](#) or send an e-mail to sales@nextgentest.com for the most up-to-date pricing and applicable discounts and incentives